

2W all-in-one DMR walkie talkie module

Product Specification



Catalogue

1. Description.....	- 3 -
2. Features.....	- 3 -
3. Application.....	- 3 -
4. Block Diagram.....	- 4 -
5. Typical Schematic Circuit.....	- 4 -
6. Electrical Characteristics.....	- 5 -
7. Interface specification.....	- 5 -
8. Functions descriptions.....	- 6 -
1) Parameter configuration.....	- 6 -
2) Brief of Serial Communication Protocol.....	- 6 -
9. Accessories.....	- 8 -
10. Pin Assignment.....	- 9 -
11. Mechanism Dimension.....	- 10 -

Note: Revision History

Revision	Date	Comment
V1.0	2016-06	First release
V1.1	2017-03	Bandwidth updated
V1.2	2017-06	Logo updated, modification of instruction
V1.3	2020-11	Update description

1. Description

DMR828 is a 2W long distance all-in-one DMR walkie talkie module. Only need external power supply and speaker, it is easy to become a professional digital walkie talkie. Simplified interface and Ultra small size make this module widely used in various applications and conveniently embedded into various handheld device.

Note:DMR828 has two vocoder versions:DMR828-NVOC & DMR828-AMBE

2. Features

- UHF band frequency: 400~470 MHz
- VHF band frequency: 134~174 MHz
- 350 band frequency: 320~400 MHz
- Distance up to 5Km
- Max power output to 2W, low power to 0.5W
- High Sensitivity:-124dBm
- Bit error rate down to 1% under -121dBm
- Independent frequency for Tx and Rx
- Analog Bandwidth: 12.5 / 25 KHz
- Digital Bandwidth: 6.25KHz
- Voice and text messages communication
- Reminder for input calling, calling status checking
- DMR /Analog walkie talkie
- Message transmission and reception
- Built-in EEPROM, data saved even powered off
- 1ppm TCXO crystal
- 51 CTCSS
- 166 CDCSS
- 9 adjustable volume
- Enhanced encryption of Voice and Text message

3. Application



4. Block Diagram

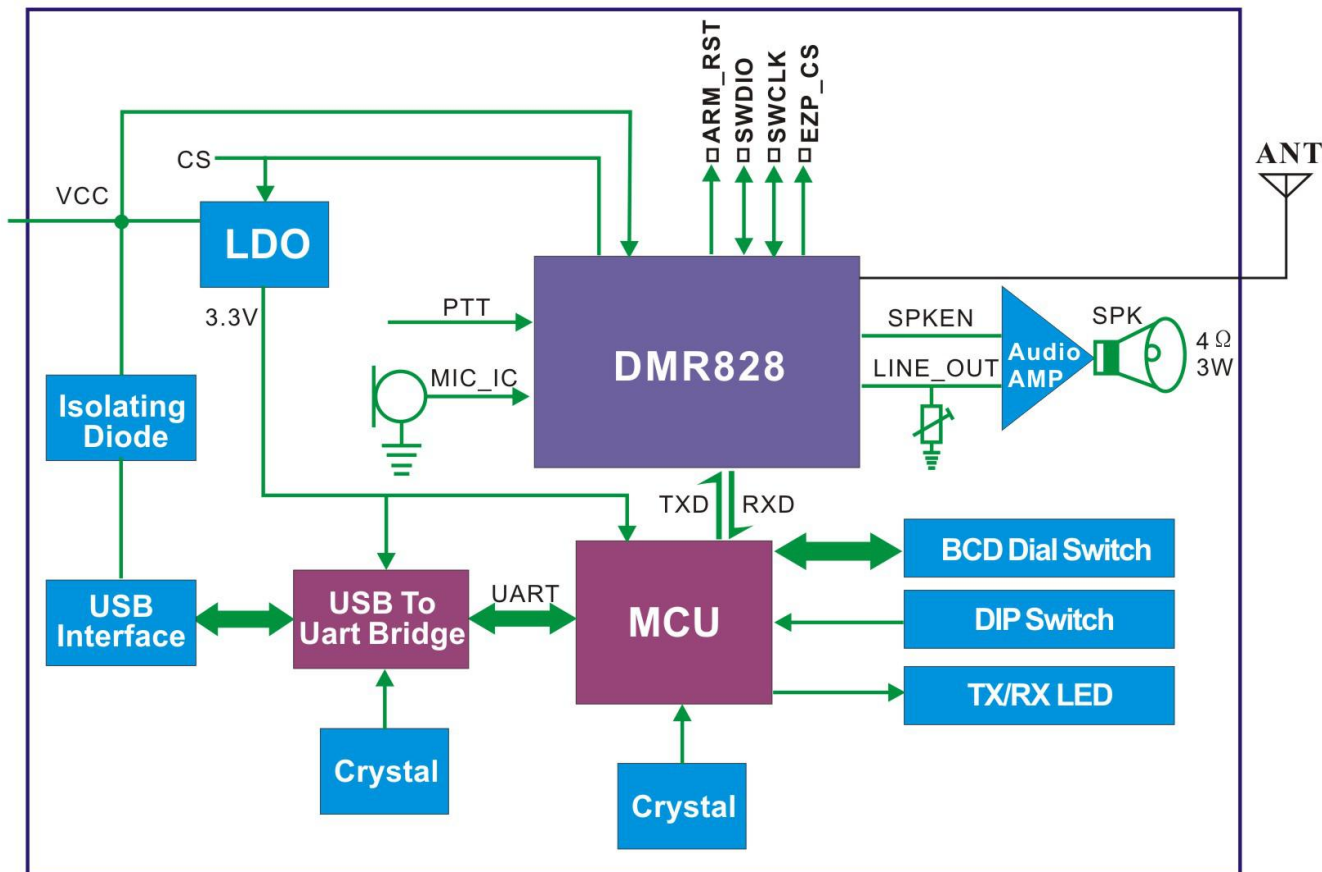

5. Typical Schematic Circuit

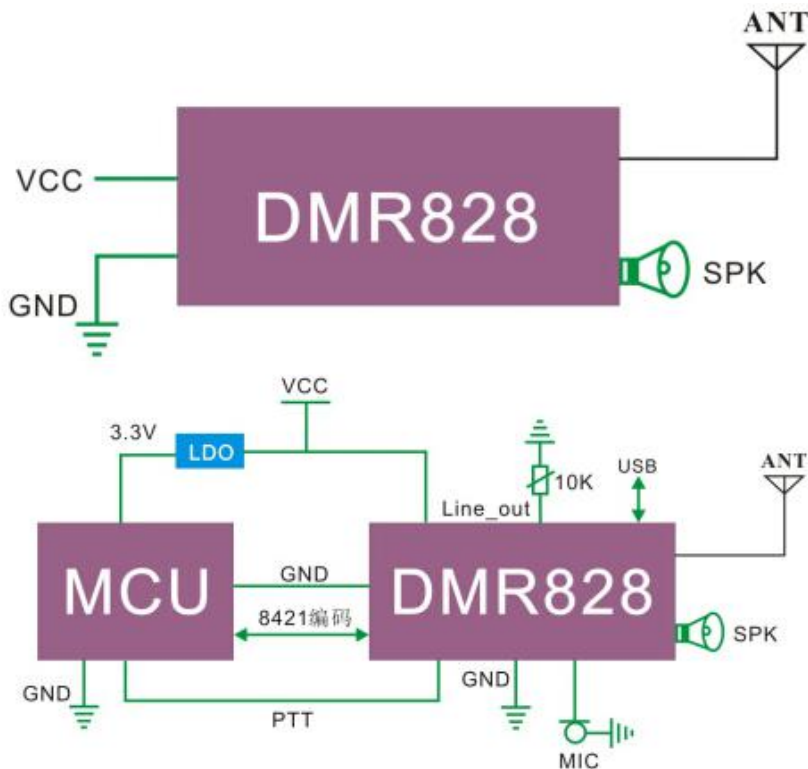

6. Electrical Characteristics

Parameters	Test condition	Min.	Typ.	Max.	Unit.
Voltage range		3.0	4.0	5.0	V
Operating Temperature		-20	25	60	°C
Frequency range	@UHF	400		470	MHz
	@VHF	134		174	MHz
	@350	320		400	MHz
Uart baud rate			57600		bps
Current Consumption					
Sleep current			75		uA
Rx current			< 135		mA
Tx current (high power)	@VCC=5.0V,2W		< 1.1		A
Tx current (high power)	@VCC=4.0V,1.5W		< 950		mA
Tx current (low power)	@VCC=4.0V, 27dBm		< 500		mA
Tx power (low power)	@VCC=4.0V		1.5		W
Tx power (low power)			500		mW
Mic input voltage			0.1	1.6	Vpp
Sensitivity			-124		dBm
Receiving BER(DMR modulation)	@ -121dBm		1		%
Audio output amplitude			2		V
Audio Output impedance			8		KOhm

7. Interface specification

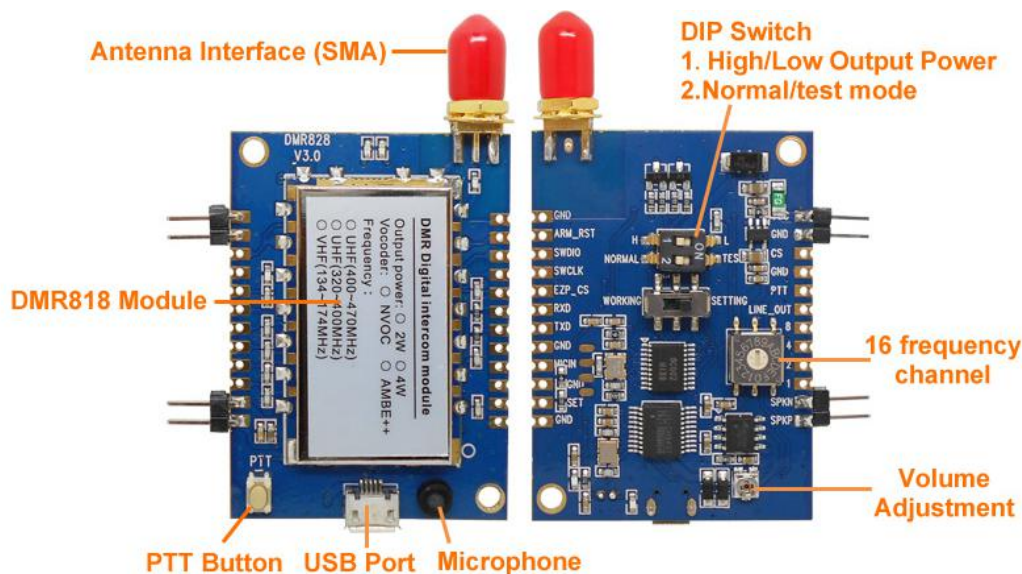

8. Functions descriptions

DMR828 has default 16 channels, CH0~CH7 in DMR mode, CH8~CHF in analog mode. All the rapameters can be configured by serial instructions.

1) Parameter configuration

DMR828 Module offers standard serial port, users can configure and read the related parameters by sending serial instructions. Module has built-in memory, all configured parameters can be saved even power off. Meanwhile, we offer PC software to customers free of charge. DMR828 can be connected with computer via USB cable or UART interface, in this way, users can configure the parameters on PC software or their own device. The connection as shown in the figure below:



**Walkie Talkie Module
TTL Interface Diagram**

- a) Install the USB Driver and PC software in computer.
- b) Connect the DMR828 module with computer via a specialized USB cable
- c) Pull the switch to setting.
- d) Module has been into setting Module at this time, show as above.

2) Brief of Serial Communication Protocol

All the parameters of DMR818 can be configured using Serial Communication Protocol.

MSB for the command.

Format as below:

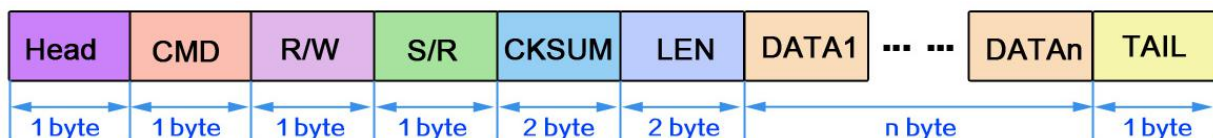

The definition of protocol as below:

Offset	Flag	Length	Comment	Detail
0	Head	1	Packet header	0x68
1	CMD	1	command	0x01~0x28: parameter function refer to table 1

2	R/W	1	Read /write operation	0x00: reading ; 0x01: writing ; (external CPU TX is writing, external CPU RX is reading) 0x02: initiative sending
3	S/R	1	Setting/Responding	setting: 0x01: start answering: 0x00 Done 0x01 busy or fail (note 2) 0x02 No channel or channel errors (note 3) 0x07 module killed 0x09 check error note: message, voice refer to below corresponding specification
4、5	CKSUM	2	Checksum	Checksum for all the packet
6、7	LEN	2	Data length	DATA length, no information, LEN is 0
8	DATA	len	Data info	
	TAIL	1	Tail of packet	0x10

Note 1: CMD as below:

CMD	Function	Message available for All channels or current channel	Message save when Power off (yes / no)
0x01	Channel change		yes
0x02	Receive volume	All	yes
0x03	scanning	current channel	no
0x04	Transceiver status checking	current channel	no
0x05	Signal strength value	current channel	no
0x06	Various call modes (Call Type)	current channel	no
0x07	Message mode setting and transmit	current channel	no
0x09	Emergency alarm	current channel	no
0x0a	Enhancements	current channel	no
0x0b	Mic Gain configuration	All	yes
0x0c	Power-saving mode configuration	All	yes
0x0d	Transceiver frequency	current channel	yes
0x0e	Repeater/off-web	current channel	no
0x10	Receive/call type, number output	current channel	no
0x11	Read received data	current channel	no
0x12	SQ setting	current channel	yes

0x13	Mode of CTCSS/CDCSS	current channel	yes
0x14	CTCSS/CDCSS	current channel	yes
0x15	Monitor switch	current channel	no
0x16	Bit Error rates		no
0x17	High/low power	current channel	yes
0x18	Contact person	current channel	no
0x19	Encryption switch	current channel	no
0x1a	Completed initialization		no
0x22	Transmit contacts information	current channel	no
0x23	Testing message	current channel	no
0x24	ID reading	all	no
0x25	Firmware Version reading	all	no
0x26	Check contacts list	all	no
0x27	Checking scan status	current channel	no
0x28	Checking encryption status	current channel	no

Note 2: When module is transmitting, receiving, and configuring, it will show 0x01 to tell setting fail for busy.

Note 3: It show 0x02 for below condition:

3.1: When change to non-exist channel;

3.2: It all happen when configure DMR settings in analog channel(such as: message, special functions) ,

3.3 : Configure analog parameters in DMR channel.

9. Accessories

The antenna is very important for RF communication, Its performance will affect the Communication, The module requires the antenna with 50Ω impedance. Universal antennas are Rod antenna, sucker antenna and telescopic antenna, User can choose the right antenna according to their application. We advise to use antennas listed on our website to get better performance.



10. Pin Assignment

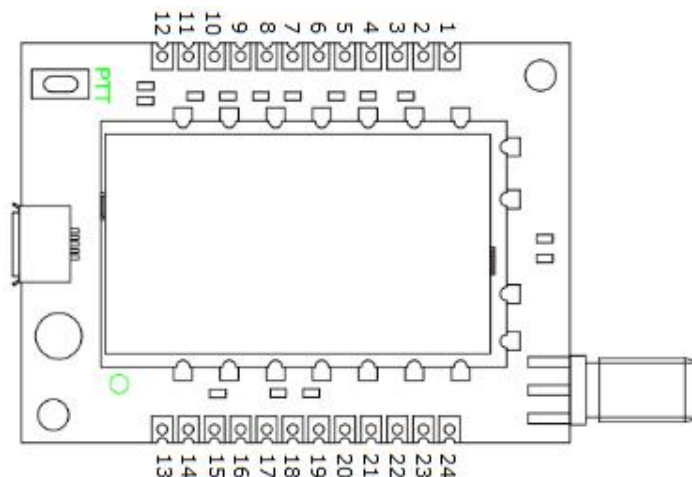

Pin NO.	Pin name	Description
1	VCC	Positive supply
2,4	GND	Ground
3	CS	Leave Open or high level for normal working, pull low to enter sleeping mode
5	PTT	Module Input, Transmitting/receiving control, pull low to force the module to enter TX state; pull high for Rx state
6	LINE_OUT	Audio output without amplified
7	8	16 Channels, Code 8421, 8th, default output “1”
8	4	16 Channels, Code 8421, 2th, default output “1”
9	2	16 Channels, Code 8421, 2nd, default output “1”
10	1	16 Channels, Code 8421, 1st, default output “1”
11	SPKN	Audio output, connect to speaker 8Ω 2W
12	SPKP	Audio output, connect to speaker 8Ω 2W
13,15,17,24	GND	Ground
14	SET	Configuration mode enable (low to enter into the setting mode, leave open or connect high level to exit setting mode) Valid when CS Pin is high or leave open.
16	MIC_IN	Microphone or line in
18	UART-TX	TXD of the module and connect to external RXD
19	UART-RX	RXD of the module and connect to external TXD
20	EZP_CS	Reserved
21	SWCLK	Reserved
22	SWDIO	Reserved
23	ARM_RST	Reserved

11. Mechanism Dimension(Unit:mm)

