

1.5W Full featured miniature walkie talkie module

## Product Specification

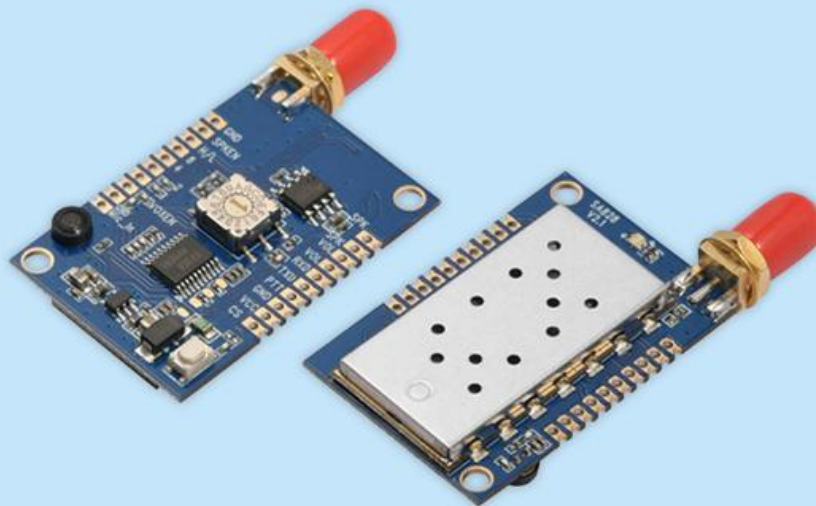

## Catalogue

1. Description .....	- 3 -
2. Features .....	- 3 -
3. Application .....	- 3 -
4. Internal block diagram .....	- 3 -
5. Interface description .....	- 4 -
6. Specification .....	- 4 -
7. Typical application schematic .....	- 5 -
8. Parameter configuration .....	- 6 -
9. Communication protocol .....	- 7 -
10. Accessories .....	- 9 -
11. Pin definition .....	- 10 -
12. Mechanism Dimension(Unit:mm) .....	- 11 -
13. Order information .....	- 11 -
14. FAQ .....	- 12 -
Appendix 1: Display and Sending Table of CTCSS/CDCSS .....	- 13 -
Appendix 2: Analog subtone comparison table .....	- 16 -
Appendix 3: SMD Reflow Chart .....	- 17 -

### Note: Revision History

Revision	Date	Comment
V1.0	2014-03-20	First release
V2.0	2015-05-28	Graphic description added
V2.1	2017-06	Logo updated
V2.2	2019-03	PCB update to V1.3
V2.3	2020-11	Update description
V2.4	2022-11	Update picture
V2.5	2023-8	Update frequency
V2.6	2024-10	Update frequency

## 1. Description

SA828 is a high cost-effective full-featured walkie talkie module with 1.5W output power, it comes with built-in high performance microcontroller, narrow band RF transceiver IC and RF power amplifier, all parameters(CTCSS, CDCSS, SQ, Predefined channels etc.) can be easily modified by PC software, Users only need to add external power supply, speaker, and audio taper, then it becomes a miniature walkie talkie with 16 adjustable channels. Simplified interface and Ultra small size make this module widely used in various applications and conveniently embedded into various handheld.

## 2. Features

- UHF Frequency : 400~480 MHz
- VHF Frequency :134~174 MHz
- 350 band frequency: 320-400MHz  
(3 frequency bands are optional)
- Tx and Rx frequency can be set alone
- Bandwidth 12.5 / 25 KHz
- High/ low power is optional  
(500mW/1.5W)
- Distance up to 4-5km in open area
- High Sensitivity: -124 dBm
- High-integrated, Small Size
- 38 CTCSS (can be set via PC software and serial port)
- 166 CDCSS  
(can be set via PC software and serial port)
- 8 level squelch
- Wide range of working voltage 3.3-5.5 V
- External potentiometer to adjust volume
- 1 ppm KDS TCXO crystal, Stable performance

## 3. Application

- Small walkie talkie
- Invisible intercom system
- audio surveillance system
- Outdoor Sport products
- building community security system

## 4. Internal block diagram

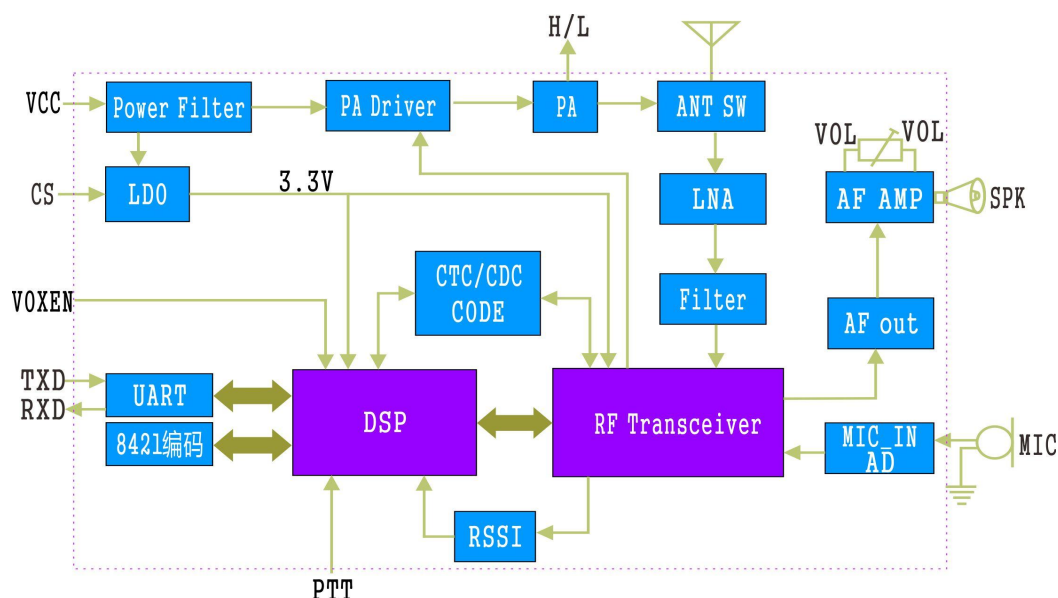

### 5. Interface description

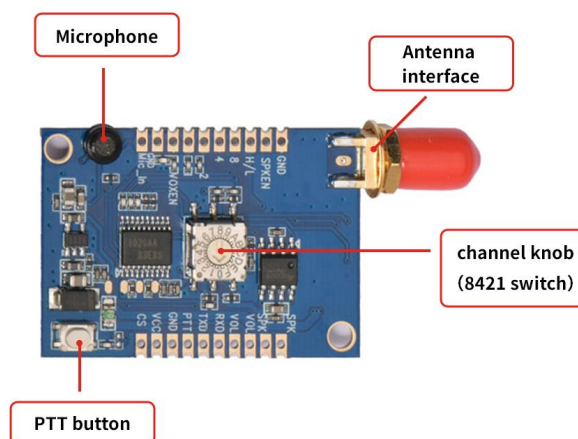

### 6. Specification

Parameter	Test condition	Min	Typ.	Max	Unit
Power supply		3.3	4.2	5.5	V
Working Temperature range		-30	25	70	°C
<b>Current Consumption</b>					
Sleep current			≤3		uA
RX current			60		mA
TX current (High power)			800	900	mA
TX current (low power)			350	450	mA
<b>Transmitting RF Parameters</b>					
Frequency range	UHF	400	450	480	MHz
	VHF	134	150	174	MHz
	350	320	350	400	MHz
Out power (high power)	@VCC=4.0V	30	31.5	32.5	dBm
Out power (low power)		25	26.5	28	dBm
modulation sensitivity	@1.5KHz/2.5KHz Frequency deviation		10		mV
Audio distortion	@1.5KHz/2.5KHz Frequency deviation		2	5	%
Signal to noise ratio	@1.5KHz/2.5KHz Frequency deviation	38	40	45	dB
Adjacent-channel power	@12.5K offset		-60dBc		dBm
CTCSS modulated frequency deviation		0.35	0.5	0.75	KHz
<b>RX frequency Parameter</b>					
RX sensitivity			-124		dBm
RX SNR	@1.5KHz Frequency deviation	45	50		dB
Audio output power			2		W
Audio output impedance			8		OHm

7. Typical application schematic

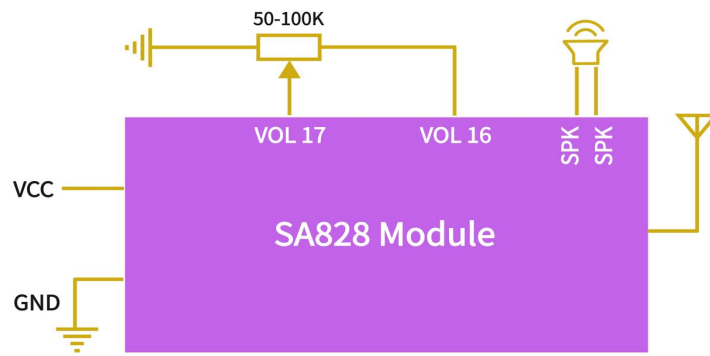

Standard Schematics

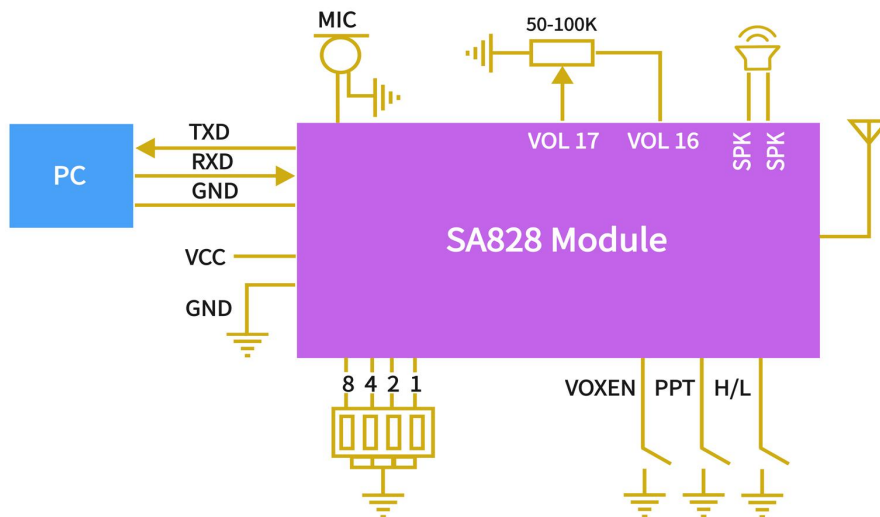

Customized Schematics

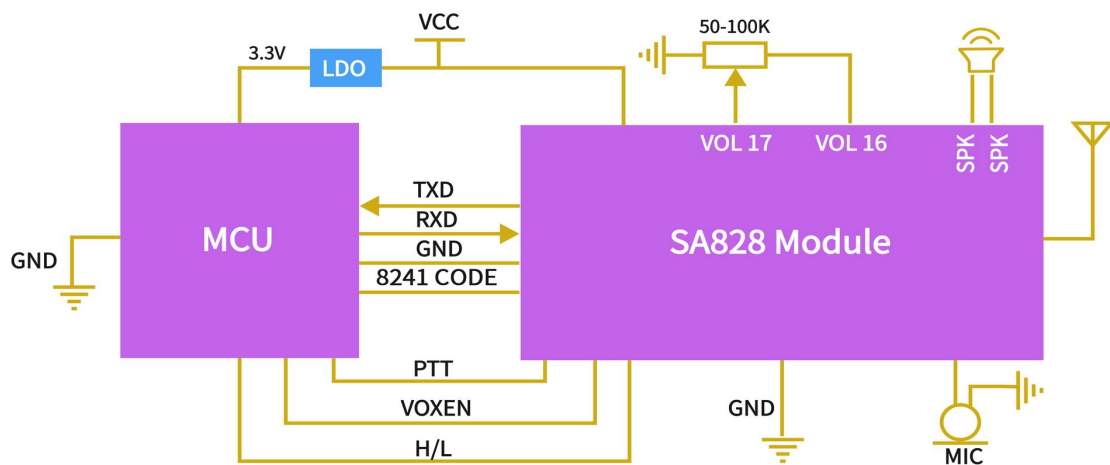

Note: The wiring of VOL pins must be correct

## 8. Parameter configuration

Module offers standard serial port, user can configure and read the related parameters by sending serial instructions. Module has built-in memory, the related configured parameters can be saved even power off. Meantime, we offer PC software to customers by free charge, users can connect module with PC software via USB bridge board, in this way, user can configure the related parameters on PC software. The connection as shown in the figure below:

**Walkie Talkie Module  
TTLInterface Diagram**

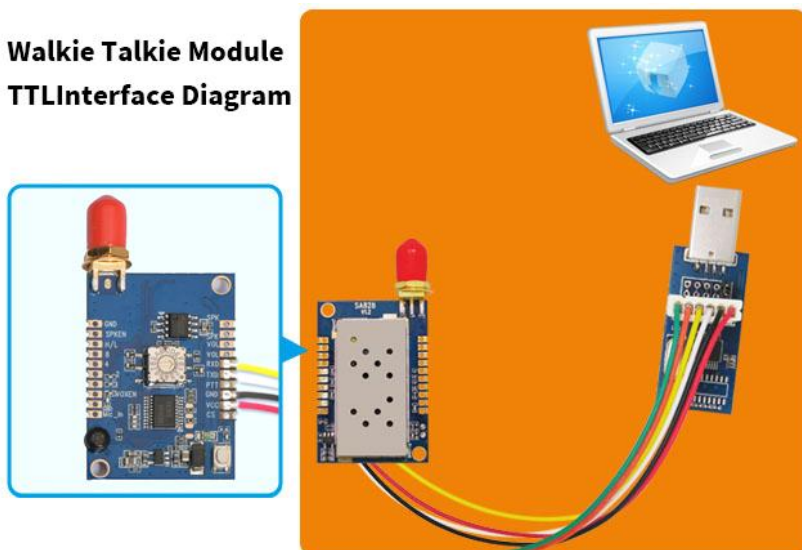

- a) Install the USB Driver and PC software in computer.
- b) Connect Module with the related interface USB bridge board through 6 pins terminal wire.
- c) Connect USB bridge board with computer (PC Software).
- d) Module has been into setting Module at this time, show as above.

PC software can read the module's parameter after connecting successfully, As shown below:

**NiceRF** 深圳市思为无线科技有限公司  
思为无线 NiceRF Wireless Technology Co., Ltd

[www.nicerf.com](http://www.nicerf.com)  
TEL: 0755-61596687

Model: SA828      Version: 1.0

**TX Channel**

Channel 1	409.7500 MHz	Channel 9	417.7500 MHz
Channel 2	410.7500 MHz	Channel 10	418.7500 MHz
Channel 3	411.7500 MHz	Channel 11	419.7500 MHz
Channel 4	412.7500 MHz	Channel 12	420.7500 MHz
Channel 5	413.7500 MHz	Channel 13	421.7500 MHz
Channel 6	414.7500 MHz	Channel 14	422.7500 MHz
Channel 7	415.7500 MHz	Channel 15	423.7500 MHz
Channel 8	416.7500 MHz	Channel 16	424.7500 MHz

**RX Channel**

Channel 1	409.7500 MHz	Channel 9	417.7500 MHz
Channel 2	410.7500 MHz	Channel 10	418.7500 MHz
Channel 3	411.7500 MHz	Channel 11	419.7500 MHz
Channel 4	412.7500 MHz	Channel 12	420.7500 MHz
Channel 5	413.7500 MHz	Channel 13	421.7500 MHz
Channel 6	414.7500 MHz	Channel 14	422.7500 MHz
Channel 7	415.7500 MHz	Channel 15	423.7500 MHz
Channel 8	416.7500 MHz	Channel 16	424.7500 MHz

COM5      CLOSE

TX CTCS: 0       TX CDCS: 023I

RX CTCS: 0       RX CDCS: 031N

S: Q: 1

SET      READ      DEFAULT

Device Found!

- ◆ TX channel: transmitting frequency , total 16 groups, Factory Default as shown in the above interface
- ◆ RX channel: receiving frequency, total 16 groups, Factory Default as shown in the above interface.
- ◆ TX CTCSS: transmitting CTCSS, 38 level for option, Factory Default is 0.
- ◆ TX CDCS: transmitting CDCSS, 166 level for option, Factory Default is 0.
- ◆ RX CTCSS: receiving CTCSS, 38 level for option, Factory Default is 0.
- ◆ RX CDCS: receiving CDCSS, 166 level for option, Factory Default is 0..
- ◆ SQ: receiving Squelch level, 8 level for option, Default is 1.
- ★ Note: For CTCSS and CDCSS ,user can choose one of them to use.

## 9. Communication protocol

Commands Format:

After module running, the standard setting of serial port as below:

Baud Rate: 9600 bps    Data Bit: 8    Stop: 1    Parity: None

Instruction return format:

Return true: OK\r\n, Return false: ERROR\r\n

Frame format Definition :

ASCII is used in communication protocol.

★ Note: CDCSS can be checked in Appendix1

### ➤ Read Module Name and Version Number

Format: AA FA A

Return Value: SAxxx\_VERx.x\r\n

Example: AA FA A (Hex: 0x41 0x41 0x46 0x41 0x41)

Return: SA828-1W\_VER1.0\r\n

(Hex: 0x53 0x41 0x36 0x31 0x30 0x5f 0x56 0x45 0x52 0x31 0x2E 0x30 0x0D 0x0A)

### ➤ Read parameter

Format: AA FA 1

Return: AA FA TFV1, RFV2, ....., TFV16, RFV16, TX\_SUBAUDIO, RX\_SUBAUDIO, SQ

## Parameters description in the Setup Group Instructions

Example: AA FA 1 (Hex 0x41 0x41 0x46 0x41 0x31 )

Return: AA

450.1250,450.1250,451.1250,451.1250,452.1250,452.1250,453.1250,453.1250,454.1250,454.1250,455.1250,455.1250,456.1250,456.1250,457.1250,457.1250,458.1250,458.1250,459.1250,459.1250,450.0250,455.0250,455.1250,455.1250,455.2250,455.2250,455.3250,455.3250,455.4250,455.4250,455.5250,455.5250,011,125,8

(Hex 41 41 34 35 30 2e 31 32 35 30 2c 34 35 30 2e 31 32 35 30 2c 34 35 31 2e 31 32 35 30 2c 34 35 31 2e 31 32 35 30 2c 34 35 32 2e 31 32 35 30 2c 34 35 33 2e 31 32 35 30 2c 34 35 33 2e 31 32 35 30 2c 34 35 34 2e 31 32 35 30 2c 34 35 35 2e 31 32 35 30 2c 34 35 35 2e 31 32 35 30 2c 34 35 36 2e 31 32 35 30 2c 34 35 36 2e 31 32 35 30 2c 34 35 37 2e 31 32 35 30 2c 34 35 37 2e 31 32 35 30 2c 34 35 38 2e 31 32 35 30 2c 34 35 38 2e 31 32 35 30 2c 34 35 39 2e 31 32 35 30 2c 34 35 39 2e 31 32 35 30 2c 34 35 35 2e 30 32 35 30 2c 34 35 35 2e 30 32 35 30 2c 34 35 35 2e 31 32 35 30 2c 34 35 35 2e 31 32 35 30 2c 34 35 35 2e 32 32 35 30 2c 34 35 35 2e 32 32 35 30 2c 34 35 35 2e 33 32 35 30 2c 34 35 35 2e 33 32 35 30 2c 34 35 35 2e 34 32 35 30 2c 34 35 35 2e 34 32 35 30 2c 34 35 35 2e 35 32 35 30 2c 34 35 35 2e 35 32 35 30 2c s30 31 31 2c 31 32 35 2c 38 0d 0a)

➤ **Set to default parameter**

Format: AA FA 2

Return Value: "OK\r\n"OR "ERROR\r\n"

Example: AA FA 2 (Hex 41 41 46 41 32 )

Return: OK\r\n (Hex 4f 4b 0d 0a)

➤ **Setup group instructions:**

Description: this command is used to tell module the information of setting parameters

Format: AA FA 3 TFV1, RFV2, ....., TFV16, RFV16, TX\_SUBAUDIO, RX\_SUBAUDIO, SQ

Parameter Description: TX\_SUBAUDIO: TX CTCSS/CDCSS

RX\_SUBAUDIO: RX CTCSS/CDCSS

SQ: Squelch level (0~8) (0: monitor mode,0 can not be used in scan mode)

(Note: TX and RX can use different CTCSS value, 000: no coding 001-038: CTCSS, 039--204: CDCSS, CDCSS displays code on the configuration software, the data and code as shown on Appendix 1)

Example: AA FA 3

450.1250,450.1250,451.1250,451.1250,452.1250,452.1250,453.1250,453.1250,454.1250,454.1250,455.1250,455.1250,456.1250,456.1250,457.1250,457.1250,458.1250,458.1250,459.1250,459.1250,455.0250,455.0250,455.1250,455.1250,455.2250,455.2250,455.3250,455.3250,455.4250,455.4250,455.5250,455.5250,011,125,8

(Hex 41 41 46 41 33 34 35 30 2e 31 32 35 30 2c 34 35 30 2e 31 32 35 30 2c 34 35 31 2e 31 32 35 30 2c 34 35 32 2e 31 32 35 30 2c 34 35 33 2e 31 32 35 30 2c 34 35 34 2e 31 32 35 30 2c 34 35 35 2e 31 32 35 30 2c 34 35 36 2e 31 32 35 30 2c 34 35 37 2e 31 32 35 30 2c 34 35 38 2e 31 32 35 30 2c 34 35 39 2e 31 32 35 30 2c 34 35 35 2e 30 32 35 30 2c 34 35 35 2e 30 32 35 30 2c 34 35 35 2e 31 32 35 30 2c 34 35 35 2e 32 32 35 30 2c 34 35 35 2e 33 32 35 30 2c 34 35 35 2e 33 32 35 30 2c 34 35 35 2e 34 32 35 30 2c 34 35 35 2e 35 32 35 30 2c 34 35 35 2e 35 32 35 30 2c s30 31 31 2c 31 32 35 2c 38 0d 0a)

Return instruction: "OK\r\n" or "ERROR\r\n"

OK\r\n (Hex 4f 4b 0d 0a)

## 10. Accessories

### 1) Antenna

The antenna is very important for RF communication. Its performance will affect the communication . The module requires the antenna with 50Ω impedance. Universal antennas are Rod antenna, sucker antenna and telescopic antenna, User can choose the right antenna according to their application. We advise to use antennas listed on our website to get better performance.

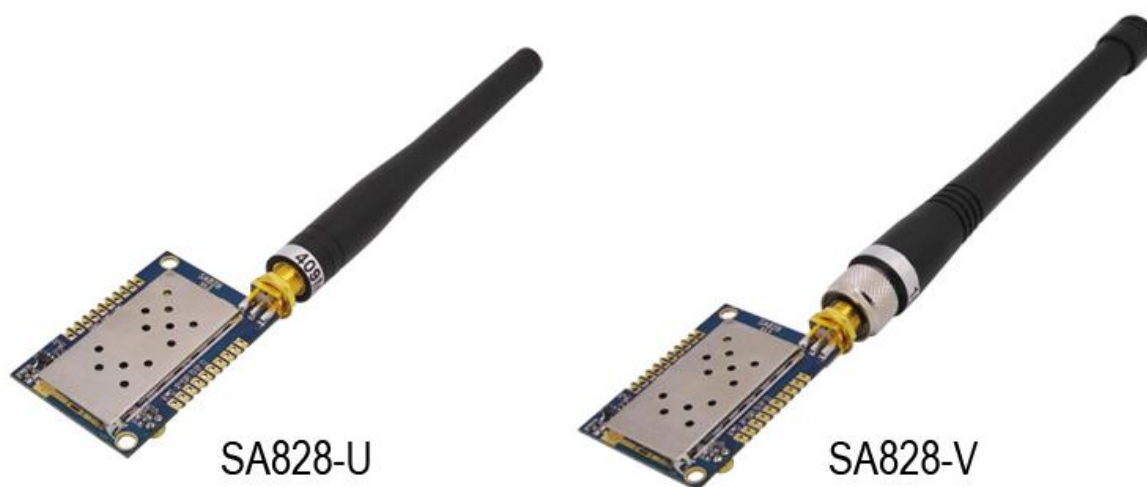

11. Pin definition

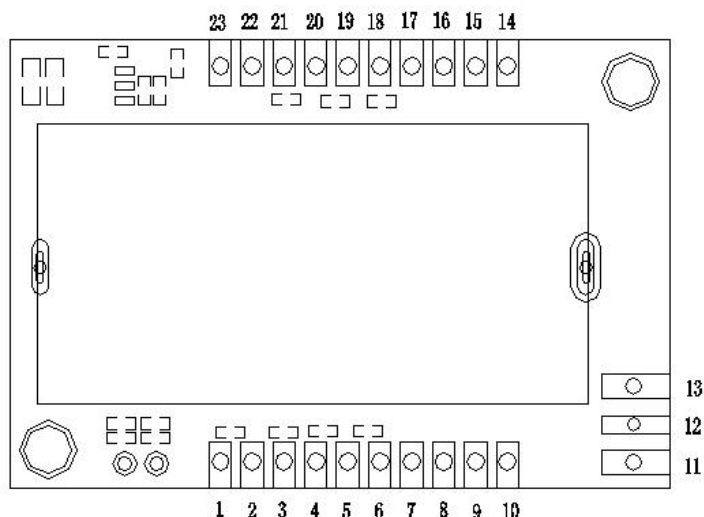

Pin NO.	Pin name	Description
1	MIC+	External microphone positive
2	MIC-	External microphone cathode
3	VOXEN	VOX enable , 0: enable VOX; leave open or 1 to disable VOX
4	1	Encoding for 16 channel, 4bit organized the 16 channels. For example, if the bit is : 0110, it is channel 6. If it is 1001, it is channel 9. The Pin marked 8 means the maximum bit. The Pin marked 1 means the lowest bit.
5	2	
6	8	
7	4	
8	H/L	High/low output power control; Leave open for high output power , low level to low output power.
9	SPKEN	Receive signal indicatie Pin, usually low level, turn high after receiving signal
10,11,13,21	GND	Exposed ground pad
12	ANT	Output for RF signal, External connect antenna with 50ohm
14,15	SPK	Output for Audio, External connect loudspeaker with 8 ohm /2W
16,17	VOL	Audio volume control, External connect 100K ohm rotary resistor
18	RXD	RXD of the module for UART, connect to TXD outside of the module
19	TXD	TXD of the module for UART, connect to RXD outside of the module
20	PTT	PTT of the walkie-talkie module, leave open or “1” is Rx, “0”is TX, Default receiving mode
22	VCC	External connect Positive supply 3.3~5V.
23	CS	“0” is for sleeping mode, ”1” for normal working, , Default normal operation

12. Mechanism Dimension(Unit:mm)

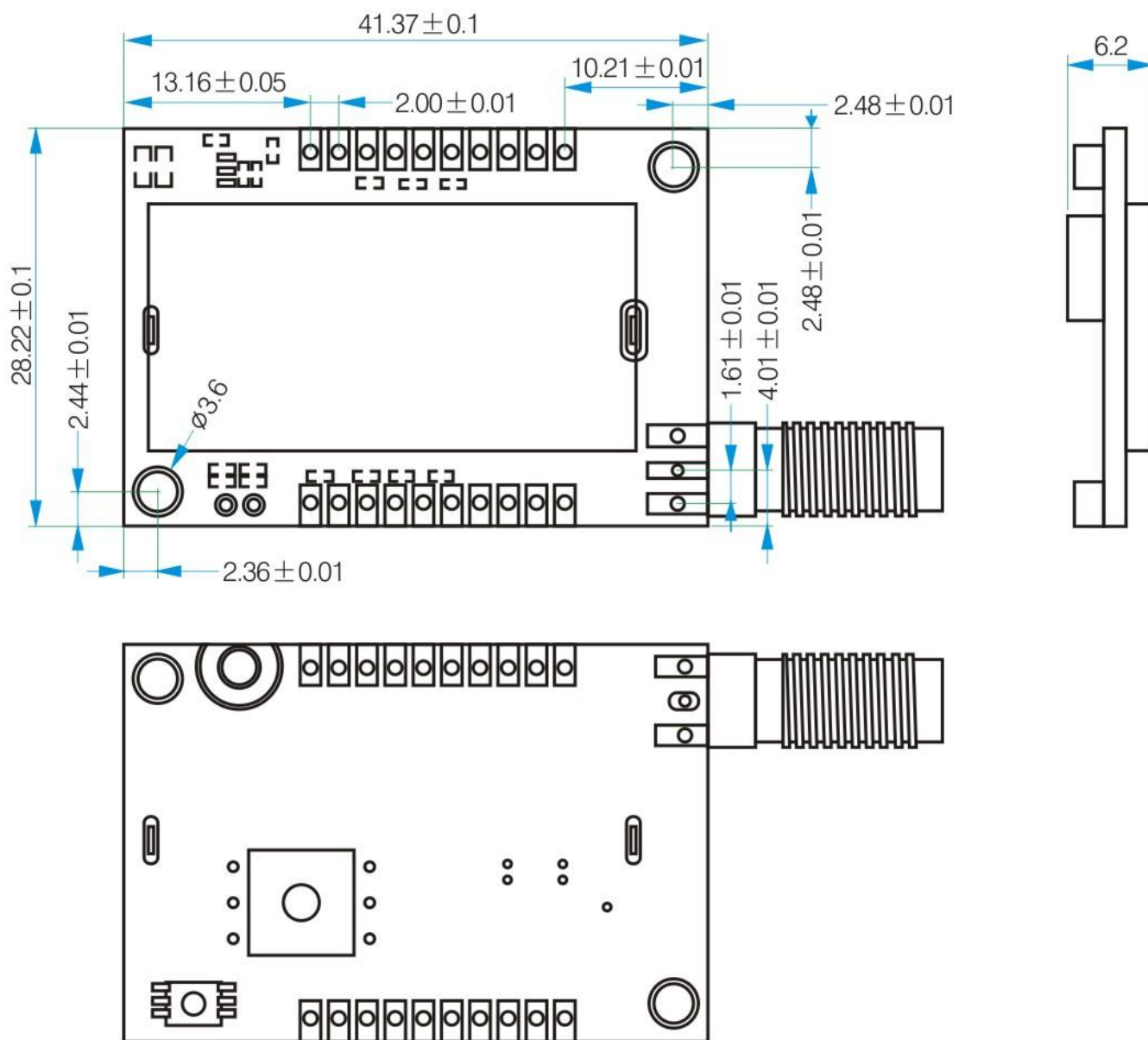

13. Order information

Product Name	Description
SA828-U	Working frequency :400~470 MHz
SA828-V	Working frequency: 134~174 MHz
SA828-350	Working frequency: 320-400 MHz

**14. FAQ**

- a) Why module can not communicate properly?
  - 1) Check if there is power connection error;
  - 2) Check if Module is in normal communication mode;
  - 3) Check if frequency, channel, and mute are same;
  - 4) Check if module is damaged;
- b) Why transmission distance is not far as it should be?
  - 1) Power supply ripple is too large;
  - 2) The antenna types do not match, or not installed properly;
  - 3) The same frequency interference;
  - 4) The surrounding environment is harsh, strong interference sources.

**Appendix 1: Display and Sending Table of CTCSS/CDCSS**

Sending	display		Sending	display		Sending	display
000	<b>0</b>		039	<b>023I</b>		122	<b>023N</b>
001	<b>1</b>		040	<b>025I</b>		123	<b>025N</b>
002	<b>2</b>		041	<b>026I</b>		124	<b>026N</b>
003	<b>3</b>		042	<b>031I</b>		125	<b>031N</b>
004	<b>4</b>		043	<b>032I</b>		126	<b>032N</b>
005	<b>5</b>		044	<b>043I</b>		127	<b>043N</b>
006	<b>6</b>		045	<b>047I</b>		128	<b>047N</b>
007	<b>7</b>		046	<b>051I</b>		129	<b>051N</b>
008	<b>8</b>		047	<b>054I</b>		130	<b>054N</b>
009	<b>9</b>		048	<b>065I</b>		131	<b>065N</b>
010	<b>10</b>		049	<b>071I</b>		132	<b>071N</b>
011	<b>11</b>		050	<b>072I</b>		133	<b>072N</b>
012	<b>12</b>		051	<b>073I</b>		134	<b>073N</b>
013	<b>13</b>		052	<b>074I</b>		135	<b>074N</b>
014	<b>14</b>		053	<b>114I</b>		136	<b>114N</b>
015	<b>15</b>		054	<b>115I</b>		137	<b>115N</b>
016	<b>16</b>		055	<b>116I</b>		138	<b>116N</b>
017	<b>17</b>		056	<b>125I</b>		139	<b>125N</b>
018	<b>18</b>		057	<b>131I</b>		140	<b>131N</b>
019	<b>19</b>		058	<b>132I</b>		141	<b>132N</b>
020	<b>20</b>		059	<b>134I</b>		142	<b>134N</b>
021	<b>21</b>		060	<b>143I</b>		143	<b>143N</b>
022	<b>22</b>		061	<b>152I</b>		144	<b>152N</b>
023	<b>23</b>		062	<b>155I</b>		145	<b>155N</b>
024	<b>24</b>		063	<b>156I</b>		146	<b>156N</b>
025	<b>25</b>		064	<b>162I</b>		147	<b>162N</b>
026	<b>26</b>		065	<b>165I</b>		148	<b>165N</b>
027	<b>27</b>		066	<b>172I</b>		149	<b>172N</b>

028	<b>28</b>		067	<b>174I</b>		150	<b>174N</b>
029	<b>29</b>		068	<b>205I</b>		151	<b>205N</b>
030	<b>30</b>		069	<b>223I</b>		152	<b>223N</b>
031	<b>31</b>		070	<b>226I</b>		153	<b>226N</b>
032	<b>32</b>		071	<b>243I</b>		154	<b>243N</b>
033	<b>33</b>		072	<b>244I</b>		155	<b>244N</b>
034	<b>34</b>		073	<b>245I</b>		156	<b>245N</b>
035	<b>35</b>		074	<b>251I</b>		157	<b>251N</b>
036	<b>36</b>		075	<b>261I</b>		158	<b>261N</b>
037	<b>37</b>		076	<b>263I</b>		159	<b>263N</b>
038	<b>38</b>		077	<b>265I</b>		160	<b>265N</b>
			078	<b>271I</b>		161	<b>271N</b>
			079	<b>306I</b>		162	<b>306N</b>
			080	<b>311I</b>		163	<b>311N</b>
			081	<b>315I</b>		164	<b>315N</b>
			082	<b>331I</b>		165	<b>331N</b>
			083	<b>343I</b>		166	<b>343N</b>
			084	<b>346I</b>		167	<b>346N</b>
			085	<b>351I</b>		168	<b>351N</b>
			086	<b>364I</b>		169	<b>364N</b>
			087	<b>365I</b>		170	<b>365N</b>
			088	<b>371I</b>		171	<b>371N</b>
			089	<b>411I</b>		172	<b>411N</b>
			090	<b>412I</b>		173	<b>412N</b>
			091	<b>413I</b>		174	<b>413N</b>
			092	<b>423I</b>		175	<b>423N</b>
			093	<b>431I</b>		176	<b>431N</b>
			094	<b>432I</b>		177	<b>432N</b>
			095	<b>445I</b>		178	<b>445N</b>
			096	<b>464I</b>		179	<b>464N</b>

			097	<b>465I</b>		180	<b>465N</b>
			098	<b>466I</b>		181	<b>466N</b>
			099	<b>503I</b>		182	<b>503N</b>
			100	<b>506I</b>		183	<b>506N</b>
			101	<b>516I</b>		184	<b>516N</b>
			102	<b>532I</b>		185	<b>532N</b>
			103	<b>546I</b>		186	<b>546N</b>
			104	<b>565I</b>		187	<b>565N</b>
			105	<b>606I</b>		188	<b>606N</b>
			106	<b>612I</b>		189	<b>612N</b>
			107	<b>624I</b>		190	<b>624N</b>
			108	<b>627I</b>		191	<b>627N</b>
			109	<b>631I</b>		192	<b>631N</b>
			110	<b>632I</b>		193	<b>632N</b>
			111	<b>654I</b>		194	<b>654N</b>
			112	<b>662I</b>		195	<b>662N</b>
			113	<b>664I</b>		196	<b>664N</b>
			114	<b>703I</b>		197	<b>703N</b>
			115	<b>712I</b>		198	<b>712N</b>
			116	<b>723I</b>		199	<b>723N</b>
			117	<b>731I</b>		200	<b>731N</b>
			118	<b>732I</b>		201	<b>732N</b>
			119	<b>734I</b>		202	<b>734N</b>
			120	<b>743I</b>		203	<b>743N</b>
			121	<b>754I</b>		204	<b>754N</b>

---



---

**Appendix 2: Analog subtone comparison table**

<b>Subtone coding</b>	1	2	3	4	5	6	7	8	9	10
<b>Sub-audio frequency</b>	67	71.9	74.4	77	79.7	82.5	85.4	88.5	91.5	94.8
<b>Subtone coding</b>	11	12	13	14	15	16	17	18	19	20
<b>Sub-audio frequency</b>	97.4	100	103.5	107.2	110.9	114.8	118.8	123	127.3	131.8
<b>Subtone coding</b>	21	22	23	24	25	26	27	28	29	30
<b>Sub-audio frequency</b>	136.5	141.3	146.2	151.4	156.7	162.2	167.9	173.8	179.9	186.2
<b>Subtone coding</b>	31	32	33	34	35	36	37	38		
<b>Sub-audio frequency</b>	192.8	203.5	210.7	218.1	225.7	233.6	241.8	250.3		

Appendix 3: SMD Reflow Chart

We recommend you should obey the IPC related standards in setting the reflow profile:

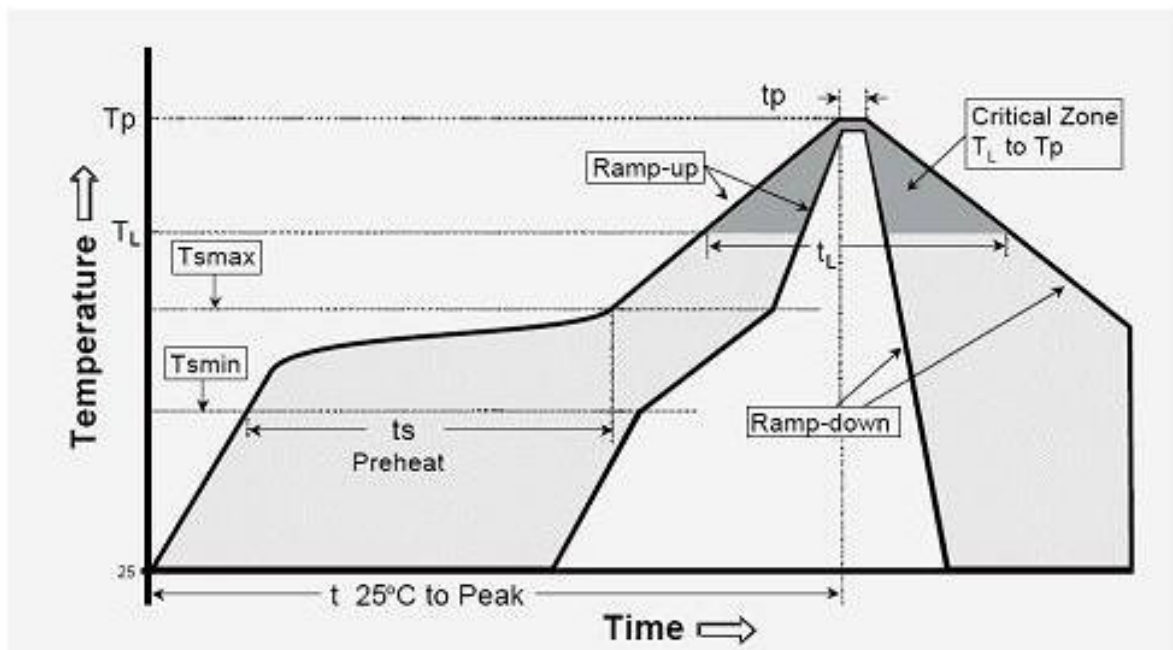

IPC/JEDEC J-STD-020B the condition for lead-free reflow soldering	big size components (thickness $\geq 2.5\text{mm}$ )
The ramp-up rate ( $T_L$ to $T_p$ )	3°C/s (max.)
preheat temperature	
- Temperature minimum ( $T_{smin}$ )	150°C
- Temperature maximum ( $T_{smax}$ )	200°C
- preheat time ( $t_s$ )	60~180s
Average ramp-up rate( $T_{smax}$ to $T_p$ )	3°C/s (Max.)
- Liquidous temperature( $T_L$ )	217°C
- Time at liquidous( $t_L$ )	60~150 second
peak temperature( $T_p$ )	245+/-5°C