

Long Range All-in-one Walkie Talkie Module
4W UHF Band

Product Specification

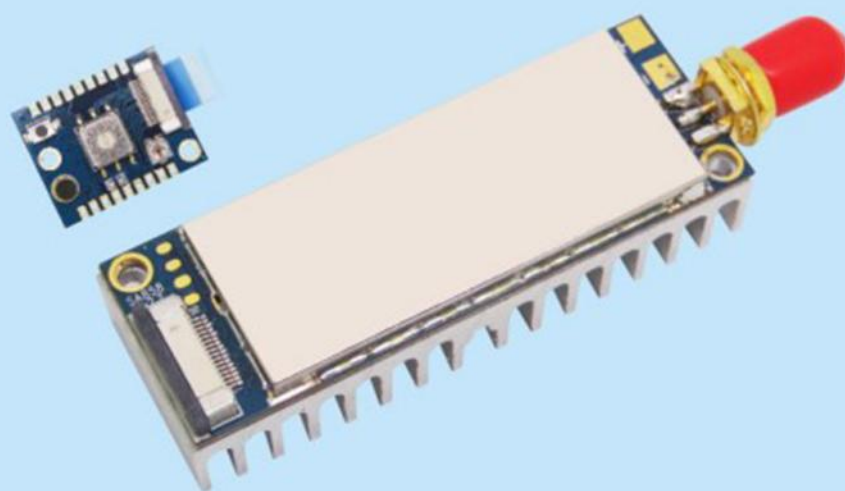

Catalogue

| | |
|--|--------|
| 1. Overview | - 3 - |
| 2. Features | - 3 - |
| 3. Application | - 3 - |
| 4. Block Diagram | - 3 - |
| 5. Electrical Characteristics | - 4 - |
| 6. Application circuit | - 5 - |
| 7. Parameter setting | - 6 - |
| 8. Communication protocol | - 7 - |
| 9. Accessories | - 9 - |
| 1) Antenna | - 9 - |
| 2) Accessory board | - 10 - |
| 3) Heat sink | - 10 - |
| 10. Pin definition | - 11 - |
| 11. Mechanical dimension(Unit:mm) | - 12 - |
| 12. Order information | - 13 - |
| 13. FAQ | - 13 - |
| Appendix 1: Display and Sending Table of CTCSS | - 14 - |
| Appendix 2: Analog subtone comparison table | - 16 - |
| Appendix 3: SMD reflow chart | - 16 - |

Note: Revision History

| Version | Date | Comment |
|---------|------------|-----------------------------------|
| V1.0 | 2015-5-20 | First release |
| V1.1 | 2016-10-10 | SA858A Mechanical dimension added |
| V1.2 | 2017-06 | Logo updated |
| V1.3 | 2018-5 | Modify the size chart |
| V1.4 | 2019-1 | Modify parameters |
| V1.5 | 2020-11 | Update description |
| V1.6 | 2023-8 | Update frequency |
| V1.7 | 2024-10 | Update frequency |

1. Overview

SA858 is a professional 4W walkie talkie module. Strong RF circuit, DSP, digital interface, and audio amplifier is built in. Besides Uart command, user can use our provided PC software to configure all the parameters. The parameters includes: Tx frequency, Rx-frequency, Tx CTCSS /CDCSS, Rx CTCSS/CDCSS , digital volume and SQ. To avoid the heating for this high power walkie talkie, we have done special handling on the software with a strong radiator added, which makes it has no problem for long time continuous working.

When SA858 is connected with SA858-PJ, it is easy to organize a professional all in one walkie talkie system, the system include 16 predefined frequency channels, adjustable volume, configurable CTCSS/CDCSS. User need only to connect with power supply and speaker.

Simplified interface and ultra small size make SA858 widely used in various applications and conveniently embedded into various handheld devices.

2. Features

- UHF band frequency : 400~480 MHz
- VHF band frequency : 134~174 MHz
- 350 band frequency: 320-400MHz
(3 frequency bands are optional)
- Tx and Rx frequency can be set alone
- Band width 12.5/25 KHz
- Output power up to 4W
- Analog volume adjustable limitless
- High / low output power selection (1W/4W)
- Distance up to 7 to 10 km in Open area
- High sensitivity: -124 dBm
- High integrated and small size
- 38 CTCSS & 166 CDCSS
(can be set by PC software and serial port)
- Wide range of working voltage 3.3-9 V
- 1ppm TCXO, stable performance
- 8 adjustable digital volume

3. Application

- Small professional walkie talkie
- Invisible intercom system
- Building community security system
- Sport products
- Handheld / Pocketable device
- Audio surveillance system

4. Block Diagram

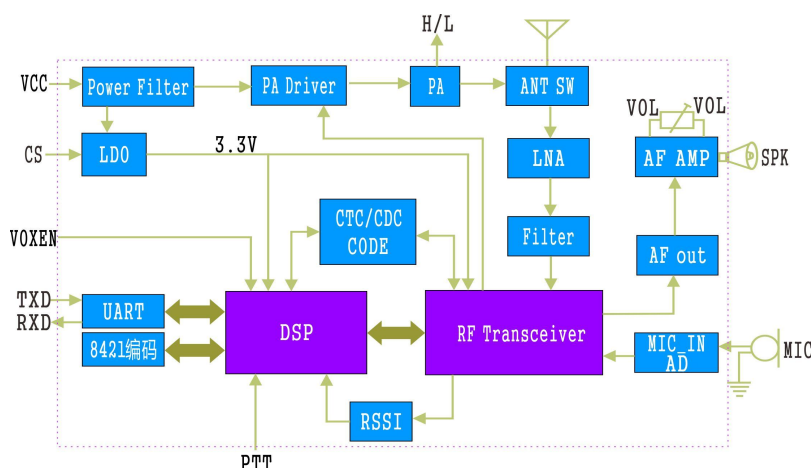

5. Electrical Characteristics

★ Note: In high level, the pins are in 3.3V.

| Parameter | Test condition | Min. | Typ | Max. | Unit |
|--------------------------------|---------------------------------------|------|------|------|------|
| Operating voltage range | -- | 3.3 | 8 | 9 | V |
| Operating temperature range | -- | -30 | 20 | 70 | °C |
| Power Consumption | | | | | |
| Sleeping Current | -- | -- | ≤3 | | uA |
| RX current | -- | -- | 60 | | mA |
| TX current (high output power) | @8v, 424.75MHz | 1400 | 1500 | | mA |
| TX current (low output power) | | 850 | 900 | | mA |
| TX current (high output power) | @4V, 424.75MHz | 1100 | 1150 | | mA |
| TX current (low output power) | | 650 | 700 | | mA |
| TX Frequency Parameter | | | | | |
| Operating frequency range | UHF | 400 | 450 | 480 | MHz |
| | VHF | 134 | 150 | 174 | MHz |
| | 350 | 320 | 350 | 400 | MHz |
| TX current (high output power) | @VCC=4.0V | 30 | 31 | 32 | dBm |
| TX current (low output power) | | 26 | 27 | 28 | dBm |
| TX current (high output power) | @VCC=8.0V | 35 | 36 | 36.5 | dBm |
| TX current (low output power) | | 30.5 | 31.5 | 32 | dBm |
| Modulation frequency | @1.5KHz/2.5KHz frequency deviation | | 10 | | mV |
| Audio modulation distortion | @1.5KHz/2.5KHz Frequency deviation | -- | 2 | 5 | % |
| Signal to Noise Ratio | @1.5KHz/2.5KHz frequency deviation | 38 | 40 | 45 | dBm |
| Adjacent Channel Ratio | @12.5K offset | -- | -60 | | dBc |
| CTCSS Modulation frequency | | 0.35 | 0.5 | 0.75 | KHz |
| RX Frequency Parameter | | | | | |
| RX sensitivity | 13dB output audio SNR | -- | -124 | -- | dBm |
| RX SNR | @1.5 KHz Frequency deviation | 45 | 50 | -- | dB |
| Audio output power | -- | -- | 2 | -- | W |
| Audio output impedance | -- | -- | 8 | -- | OHm |

6. Application circuit

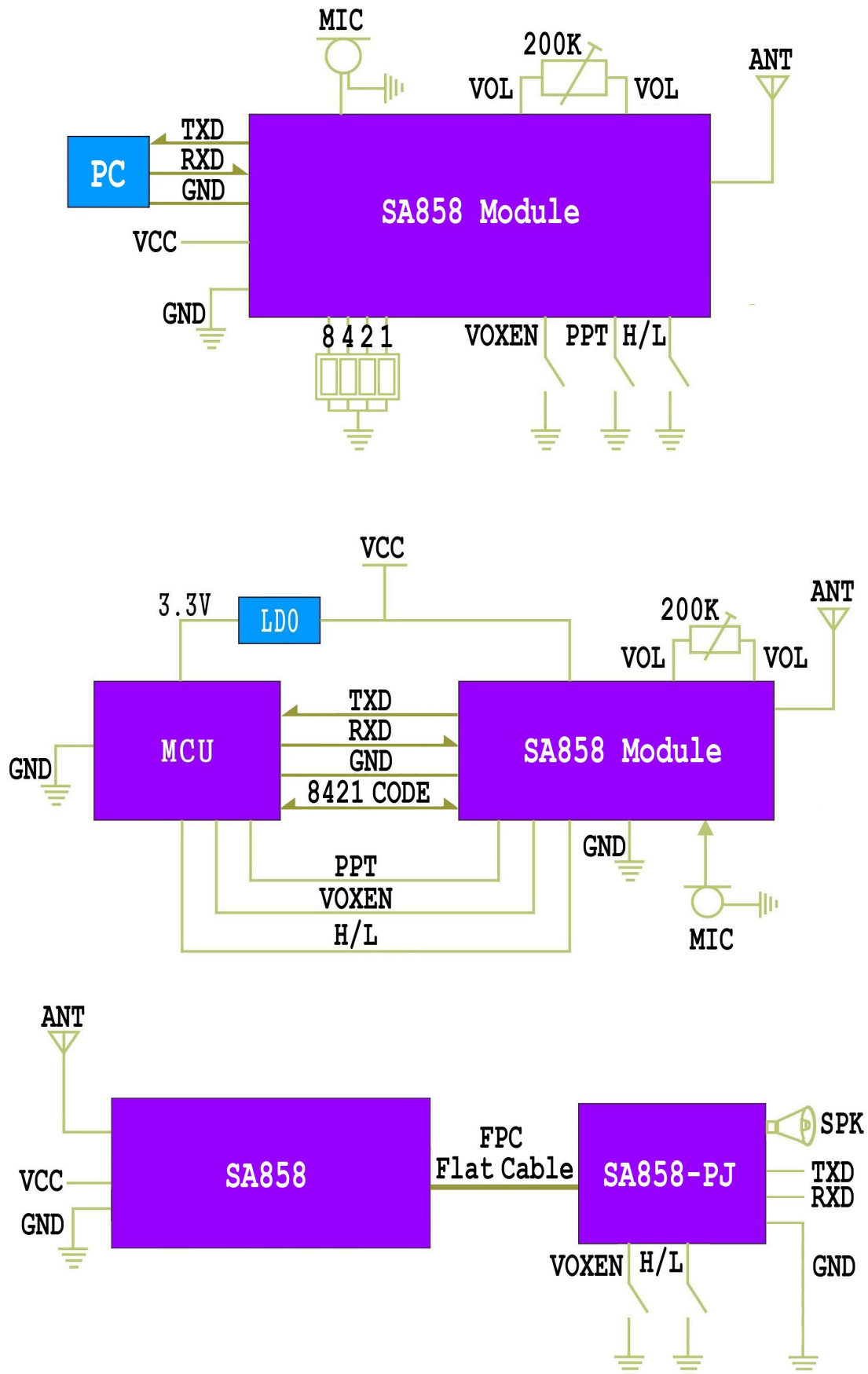

7. Parameter setting

SA858 module provides a standard UART interface for users to configure and read the parameters. Module has integrated memory unit, all setting parameters can be saved when power off. Through USB bridge board, users can connect module with PC device, and we will provide with PC software free for users to configure the inner frequency. It is very easy to use. Wire connecting method is as below:

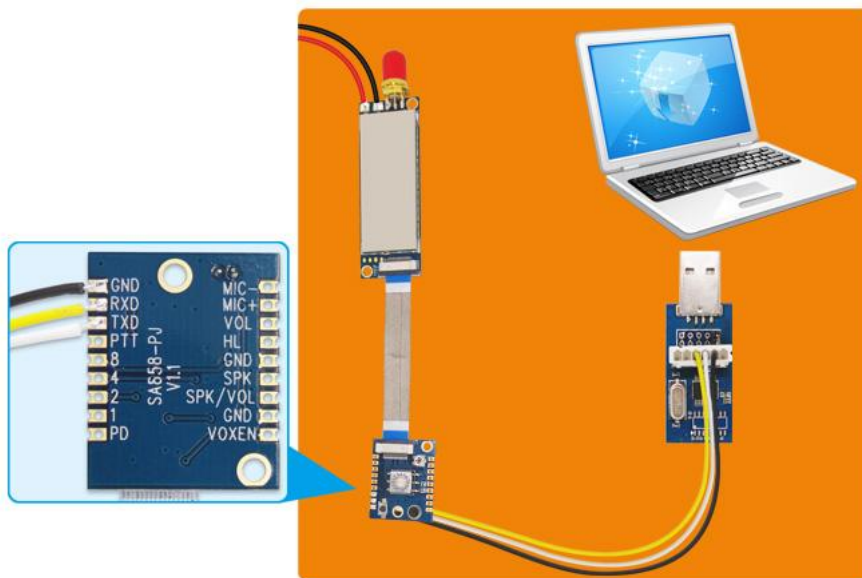

Walkie Talkie Module TTL Interface Diagram

- a) Install the USB Driver and PC software in computer.
- b) Connect Module with the related interface on USB Bridge Board through 6 pins terminal wire. Also, connect module with DC power.
- c) Connect module with computer (PC software) through USB bridge Board.
- d) Module has been into setting mode at this time, show as above.

After connected successfully, PC device can read the current parameters, show as below:



- ◆ TX channel: TX frequency, 16 group, default factory set is as above interface.
 - ◆ RX channel: RX frequency, 16 group, default factory set is as above interface.。
 - ◆ TX CTCSS: TX imitation silent letter, 38 level to choose, default set is 0.
 - ◆ TX CDCS: TX digital silent letter, 166 level to choose, default set is none.
 - ◆ RX CTCSS: RX imitation silent letter, 38 level to choose, default set is 0.
 - ◆ RX CDCS: digital silent letter, 166 level to choose, default set is none.
 - ◆ SQ: RX Squelch Level, 8 level to choose, default is 1。
- ★ Note: Users can only choose one of CTCSS or CDCS.

8.Communication protocol

Commands Format:

After module is working, the UART parameters to send the command are fixed to:

Baud Rate: 9600 bps Data Bit: 8 Stop: 1 Parity: None

Commands return format:

Return succeeded: OK\r\n, failed: ERROR\r\n

Frame format definition:

All commands in communication protocol are sending by ASCII code.

★ Note: Specific CTCSS correspond value view on Appendix 1.

➤ Read Module Name and Version Number

Format: AA FA A

Return Value: SAxxx_VERx.x\r\n

Example: AA FA A (Hex: 0x41 0x41 0x46 0x41 0x41)

Return: SA858_VER1.0\r\n

(Hex: 0x53 0x41 0x36 0x31 0x30 0x5f 0x56 0x45 0x52 0x31 0x2E 0x30 0x0D 0x0A)

➤ Read parameter

Format: AA FA 1

Return: AA FA TFV1, RFV2,, TFV16, RFV16, TX_SUBAUDIO, RX_SUBAUDIO, SQ

Parameters instruction is in setting group commands.

Example: AA FA 1 (Hex: 0x41 0x41 0x46 0x41 0x31)

Return: AA

450.1250,450.1250,451.1250,451.1250,452.1250,452.1250,453.1250,453.1250,454.1250,454.1250,455.1250,455.1250,456.1250,456.1250,457.1250,457.1250,458.1250,458.1250,459.1250,459.1250,455.0250,455.0250,455.1250,455.1250,455.2250,455.2250,455.3250,455.3250,455.4250,455.4250,455.5250,455.5250,011,125,8

(Hex: 41 41 34 35 30 2e 31 32 35 30 2c 34 35 30 2e 31 32 35 30 2c 34 35 31 2e 31 32 35 30 2c 34 35 31 2e 31 32 35 30 2c 34 35 32 2e 31 32 35 30 2c 34 35 32 2e 31 32 35 30 2c 34 35 33 2e 31 32 35 30 2c 34 35 33 2e 31 32 35 30 2c 34 35 34 2e 31 32 35 30 2c 34 35 34 2e 31 32 35 30 2c 34 35 35 2e 31 32 35 30 2c 34 35 35 2e 31 32 35 30 2c 34 35 36 2e 31 32 35 30 2c 34 35 36 2e 31 32 35 30 2c 34 35 37 2e 31 32 35 30 2c 34 35 37 2e 31 32 35 30 2c 34 35 38 2e 31 32 35 30 2c 34 35 38 2e 31 32 35 30 2c 34 35 39 2e 31 32 35 30 2c 34 35 39 2e 31 32 35 30 2c 34 35 35 2e 30 32 35 30 2c 34 35 35 2e 30 32 35 30 2c 34 35 35 2e 31 32 35 30 2c 34 35 35 2e 31 32 35 30 2c 34 35 35 2e 32 32 35 30 2c 34 35 35 2e 32 32 35 30 2c 34 35 35 2e 33 32 35 30 2c 34 35 35 2e 33 32 35 30 2c 34 35 35 2e 34 32 35 30 2c 34 35 35 2e 34 32 35 30 2c 34 35 35 2e 35 32 35 30 2c 34 35 35 2e 35 32 35 30 2c s30 31 31 2c 31 32 35 2c 38 0d 0a)

➤ Set to default parameter

Format: AA FA 2

Return: "OK\r\n" or "ERROR\r\n"

Example: AA FA 2 (Hex: 41 41 46 41 32)

Return: OK\r\n (Hex: 4f 4b 0d 0a)

➤ Setting group commands:

Description: This command is to tell the module working parameter settings information.

Format: AA FA 3 Tfv1, Rfv2,, Tfv16, Rfv16, TX_SUBAUDIO, RX_SUBAUDIO, SQ

Parameter description:

TX_SUBAUDIO: Send CTCSS value

RX_SUBAUDIO: Receive CTCSS value

SQ: Squelch level(0~8) (0: monitor mode, can not used in scan mode)

(Note: Transmitter and receiver can use different CTCSS value, 000: no code 001—038: CTCSS, 039—204: Display and Sending Table of CTCSS, CDCSS view on Appendix 1)

Example: AA FA 3

450.1250,450.1250,451.1250,451.1250,452.1250,452.1250,453.1250,453.1250,454.1250,454.1250,455.1250,455.1250,456.1250,456.1250,457.1250,457.1250,458.1250,458.1250,459.1250,459.1250,455.0250,4

55.0250,455.1250,455.1250,455.2250,455.2250,455.3250,455.3250,455.4250,455.4250,455.5250,455.5250,011,125,8

(Hex: 41 41 46 41 33 34 35 30 2e 31 32 35 30 2c 34 35 30 2e 31 32 35 30 2c 34 35 31 2e 31 32 35 30 2c 34 35 31 2e 31 32 35 30 2c 34 35 32 2e 31 32 35 30 2c 34 35 32 2e 31 32 35 30 2c 34 35 33 2e 31 32 35 30 2c 34 35 33 2e 31 32 35 30 2c 34 35 34 2e 31 32 35 30 2c 34 35 34 2e 31 32 35 30 2c 34 35 35 2e 31 32 35 30 2c 34 35 35 2e 31 32 35 30 2c 34 35 36 2e 31 32 35 30 2c 34 35 36 2e 31 32 35 30 2c 34 35 37 2e 31 32 35 30 2c 34 35 37 2e 31 32 35 30 2c 34 35 38 2e 31 32 35 30 2c 34 35 38 2e 31 32 35 30 2c 34 35 39 2e 31 32 35 30 2c 34 35 39 2e 31 32 35 30 2c 34 35 35 2e 30 32 35 30 2c 34 35 35 2e 30 32 35 30 2c 34 35 35 2e 31 32 35 30 2c 34 35 35 2e 31 32 35 30 2c 34 35 35 2e 32 32 35 30 2c 34 35 35 2e 32 32 35 30 2c 34 35 35 2e 33 32 35 30 2c 34 35 35 2e 33 32 35 30 2c 34 35 35 2e 34 32 35 30 2c 34 35 35 2e 34 32 35 30 2c 34 35 35 2e 35 32 35 30 2c 34 35 35 2e 35 32 35 30 2c s30 31 31 2c 31 32 35 2c 38 0d 0a)

Return commands: "OK\r\n" or "ERROR\r\n"

OK\r\n (Hex: 4f 4b 0d 0a)

9. Accessories

1) Antenna

Antenna is an important part in communication system. Its performance will influence the whole communication system. This module requires antennas impedance in 50ohm. Regular used antenna is rubber straight antenna, sucker antenna, telescopic antenna and so on. Users can choose the antenna according to the application environment. To make sure modules in the best working mode, we recommend the antennas from our company.



2) Accessory board

To make it convenient to use, we have an accessory board SA858-PJ which can be used with SA858 walkie talkie module, the small board extend the pins of the module by the special FPC, the board has integrated with microphone, channel knob, volume knob, PTT button and other device, Users only need to add an external speaker so that it can be used as a high power and micro walkie talkie. Accessory board as below:

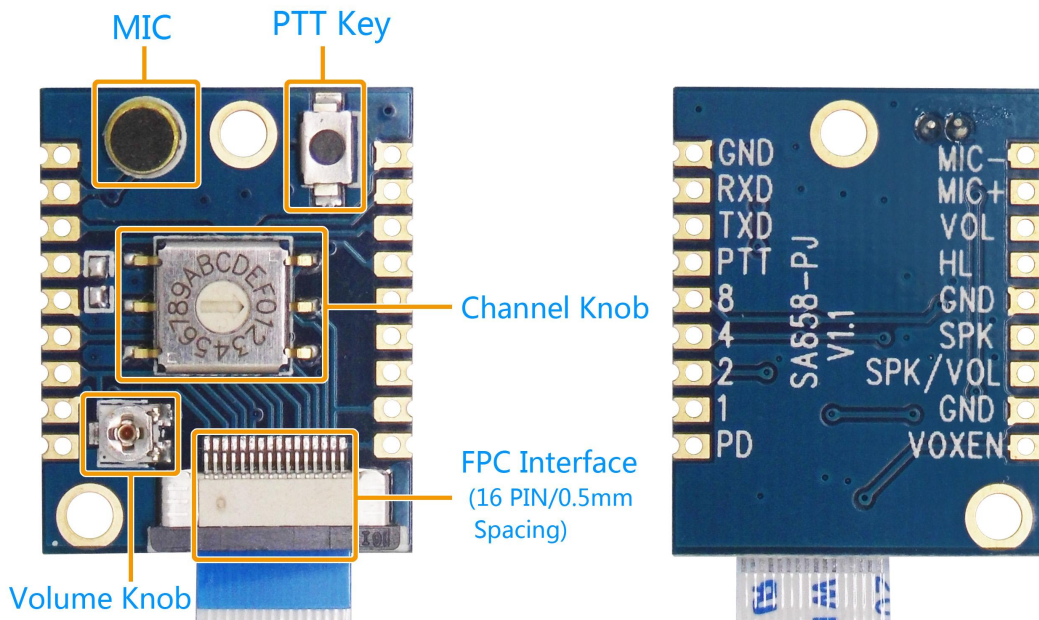

3) Heat sink

This walkie talkie module is a high power wireless device, it will has bigger current during transmitting, so we have equipped module with a specialized heat sink to make sure module can get the best performance when it is generate heat in a long time, show as below:

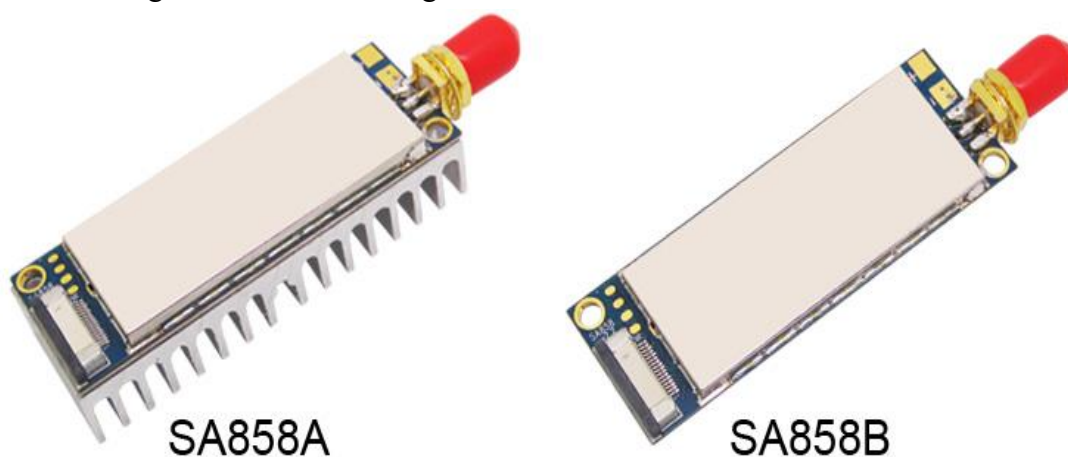

★ Note: If users have their own heat sink device, or our standard heat sink dimension is not suitable for the application, they can also choose bare module without radiator (SA858B)..

10. Pin definition



| Pin No. | Pin name | Description |
|---------|----------|---|
| 1 | MIC+ | Connect positive of external microphone |
| 2 | GND | Connect negative of external microphone or power ground |
| 3 | SPK/VOL | Eternal connect 8 ohm and 2W speaker and volume adjust electronic equipment |
| 4 | SPK | Audio output pin, external connect 8ohm and 2W speaker |
| 5 | H/L | RF high and lower power pin, connect“0” is lower power, off is high power |
| 6 | VOL | Audio volume adjust pin, external connect 200K adjustable electronic equipment |
| 7 | GND | External connect negative power |
| 8 | RXD | Data receive serial port |
| 9 | TXD | Data send serial port |
| 10 | VOXEN | Volume enable pin, “0” is open volume control function, “1”is close, default is“1” |
| 11 | PTT | Send/receive control pin, “0”is send; “1” is receive, default is receive |
| 12 | 8 | Frequency 16 channels, 8421code, No.8 bits, default is“1”output |
| 13 | 4 | Frequency 16 channels, 8421code, No.4 bits, default is“1”output |
| 14 | 2 | Frequency 16 channels, 8421code, No.2 bits, default is“1”output |
| 15 | 1 | Frequency 16 channels, 8421code, No.1 bit, default is“1”output |
| 16 | PD | Module sleep enable, “0” is sleep mode; “1”normal working, default is normal working mode |
| 17 | VCC | Connect positive power |
| 18 | GND | Connect negative power |
| 19, 21 | GND | Connect antenna ground |
| 20 | ANT | RF signal output, external connect 50ohm antenna |

11. Mechanical dimension(Unit:mm)

SA858A:

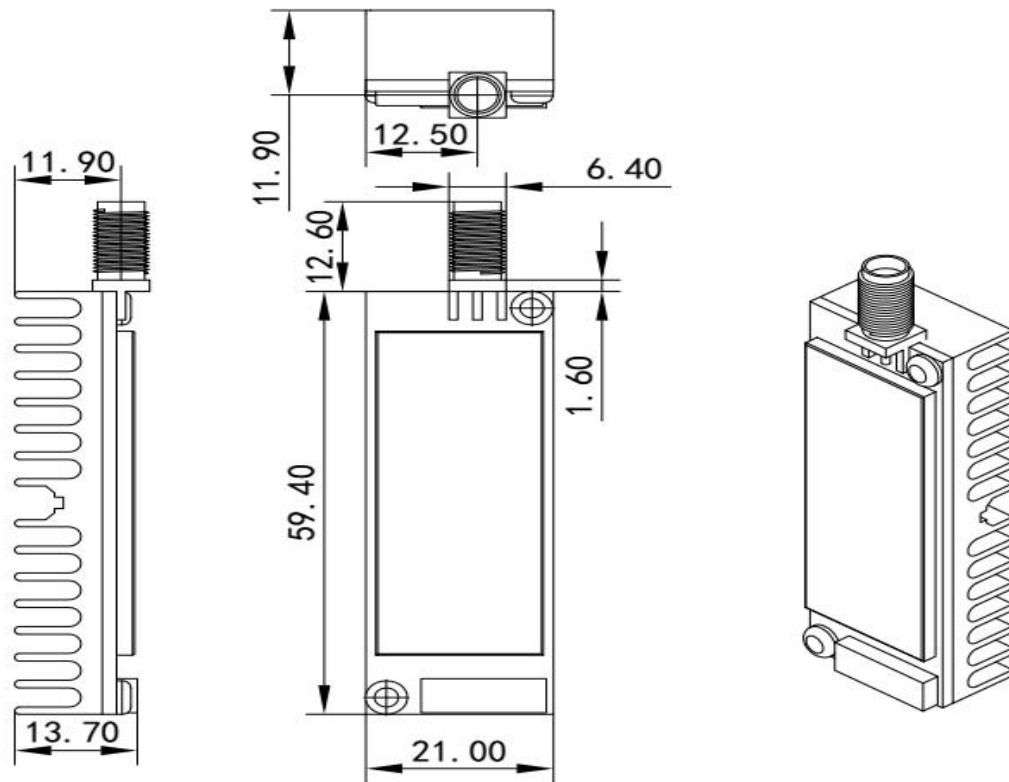

SA858B、SA858-PJ:

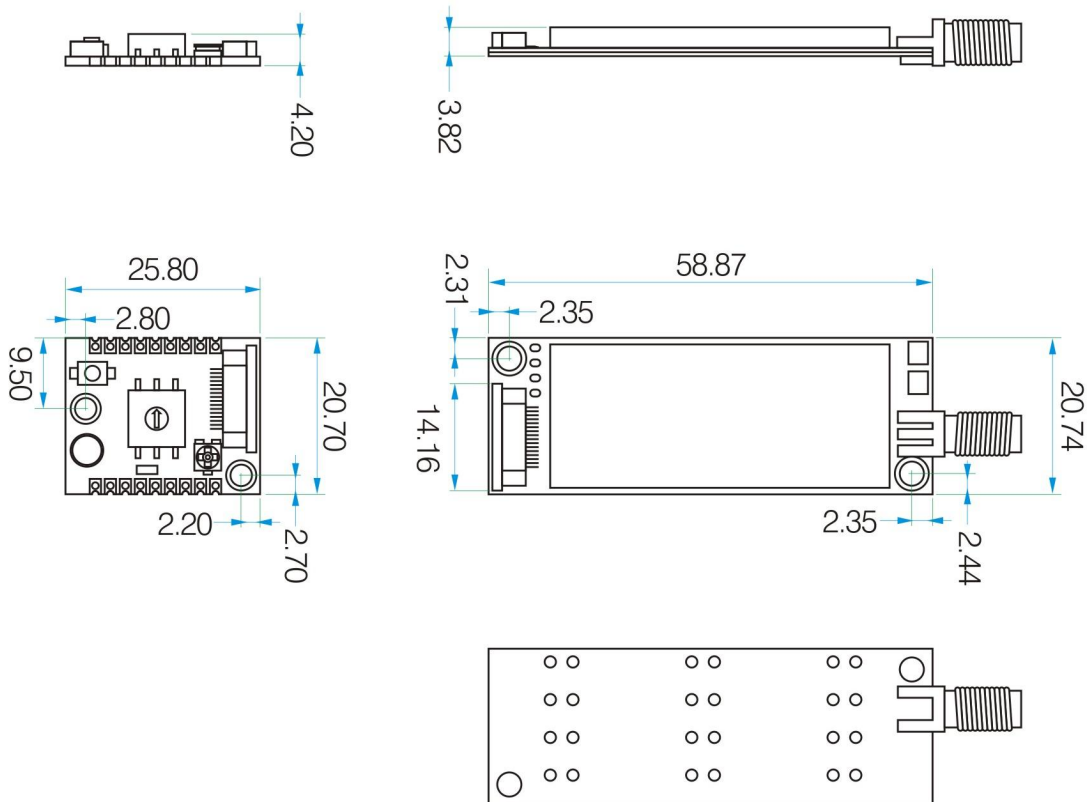

12. Order information

| Out factory item | Description |
|------------------|---|
| SA858A | High power walkie talkie module with heat sink |
| SA858B | High power walkie talkie bare module board without heat sink |
| SA858-PJ | Module accessory, integrated channel knob, volume knob, microphone and PTT button |

13. FAQ

a) Why modules cannot communicate properly?

- 1) Check if there is a power connect error;
- 2) Check if modules are in normal communication mode;
- 3) Check if all module are setting in the same frequency, channel and CTCSS;
- 4) Check if modules are broken.

b) Why the transceiver distance is not as far as it supposed?

- 1) Check if the power ripple is too high;
- 2) Check if the antenna is not match or installed incorrectly;
- 3) Check if there is same frequency interference surround, or there is a bad environment, or strong interference source.

Appendix 1: Display and Sending Table of CTCSS

| Send | Display | | Send | Display | | Send | Display |
|------|-----------|--|------|-------------|--|------|-------------|
| 000 | 0 | | 039 | 023I | | 122 | 023N |
| 001 | 1 | | 040 | 025I | | 123 | 025N |
| 002 | 2 | | 041 | 026I | | 124 | 026N |
| 003 | 3 | | 042 | 031I | | 125 | 031N |
| 004 | 4 | | 043 | 032I | | 126 | 032N |
| 005 | 5 | | 044 | 043I | | 127 | 043N |
| 006 | 6 | | 045 | 047I | | 128 | 047N |
| 007 | 7 | | 046 | 051I | | 129 | 051N |
| 008 | 8 | | 047 | 054I | | 130 | 054N |
| 009 | 9 | | 048 | 065I | | 131 | 065N |
| 010 | 10 | | 049 | 071I | | 132 | 071N |
| 011 | 11 | | 050 | 072I | | 133 | 072N |
| 012 | 12 | | 051 | 073I | | 134 | 073N |
| 013 | 13 | | 052 | 074I | | 135 | 074N |
| 014 | 14 | | 053 | 114I | | 136 | 114N |
| 015 | 15 | | 054 | 115I | | 137 | 115N |
| 016 | 16 | | 055 | 116I | | 138 | 116N |
| 017 | 17 | | 056 | 125I | | 139 | 125N |
| 018 | 18 | | 057 | 131I | | 140 | 131N |
| 019 | 19 | | 058 | 132I | | 141 | 132N |
| 020 | 20 | | 059 | 134I | | 142 | 134N |
| 021 | 21 | | 060 | 143I | | 143 | 143N |
| 022 | 22 | | 061 | 152I | | 144 | 152N |
| 023 | 23 | | 062 | 155I | | 145 | 155N |
| 024 | 24 | | 063 | 156I | | 146 | 156N |
| 025 | 25 | | 064 | 162I | | 147 | 162N |
| 026 | 26 | | 065 | 165I | | 148 | 165N |
| 027 | 27 | | 066 | 172I | | 149 | 172N |
| 028 | 28 | | 067 | 174I | | 150 | 174N |
| 029 | 29 | | 068 | 205I | | 151 | 205N |
| 030 | 30 | | 069 | 223I | | 152 | 223N |
| 031 | 31 | | 070 | 226I | | 153 | 226N |
| 032 | 32 | | 071 | 243I | | 154 | 243N |
| 033 | 33 | | 072 | 244I | | 155 | 244N |
| 034 | 34 | | 073 | 245I | | 156 | 245N |
| 035 | 35 | | 074 | 251I | | 157 | 251N |
| 036 | 36 | | 075 | 261I | | 158 | 261N |
| 037 | 37 | | 076 | 263I | | 159 | 263N |
| 038 | 38 | | 077 | 265I | | 160 | 265N |
| | | | 078 | 271I | | 161 | 271N |
| | | | 079 | 306I | | 162 | 306N |

| | | | | | | | |
|--|--|--|-----|-------------|--|-----|-------------|
| | | | 080 | 311I | | 163 | 311N |
| | | | 081 | 315I | | 164 | 315N |
| | | | 082 | 331I | | 165 | 331N |
| | | | 083 | 343I | | 166 | 343N |
| | | | 084 | 346I | | 167 | 346N |
| | | | 085 | 351I | | 168 | 351N |
| | | | 086 | 364I | | 169 | 364N |
| | | | 087 | 365I | | 170 | 365N |
| | | | 088 | 371I | | 171 | 371N |
| | | | 089 | 411I | | 172 | 411N |
| | | | 090 | 412I | | 173 | 412N |
| | | | 091 | 413I | | 174 | 413N |
| | | | 092 | 423I | | 175 | 423N |
| | | | 093 | 431I | | 176 | 431N |
| | | | 094 | 432I | | 177 | 432N |
| | | | 095 | 445I | | 178 | 445N |
| | | | 096 | 464I | | 179 | 464N |
| | | | 097 | 465I | | 180 | 465N |
| | | | 098 | 466I | | 181 | 466N |
| | | | 099 | 503I | | 182 | 503N |
| | | | 100 | 506I | | 183 | 506N |
| | | | 101 | 516I | | 184 | 516N |
| | | | 102 | 532I | | 185 | 532N |
| | | | 103 | 546I | | 186 | 546N |
| | | | 104 | 565I | | 187 | 565N |
| | | | 105 | 606I | | 188 | 606N |
| | | | 106 | 612I | | 189 | 612N |
| | | | 107 | 624I | | 190 | 624N |
| | | | 108 | 627I | | 191 | 627N |
| | | | 109 | 631I | | 192 | 631N |
| | | | 110 | 632I | | 193 | 632N |
| | | | 111 | 654I | | 194 | 654N |
| | | | 112 | 662I | | 195 | 662N |
| | | | 113 | 664I | | 196 | 664N |
| | | | 114 | 703I | | 197 | 703N |
| | | | 115 | 712I | | 198 | 712N |
| | | | 116 | 723I | | 199 | 723N |
| | | | 117 | 731I | | 200 | 731N |
| | | | 118 | 732I | | 201 | 732N |
| | | | 119 | 734I | | 202 | 734N |
| | | | 120 | 743I | | 203 | 743N |
| | | | 121 | 754I | | 204 | 754N |

Appendix 2: Analog subtone comparison table

| | | | | | | | | | | |
|---------------------|-------|-------|-------|-------|-------|-------|-------|-------|-------|-------|
| Subtone coding | 1 | 2 | 3 | 4 | 5 | 6 | 7 | 8 | 9 | 10 |
| Sub-audio frequency | 67 | 71.9 | 74.4 | 77 | 79.7 | 82.5 | 85.4 | 88.5 | 91.5 | 94.8 |
| Subtone coding | 11 | 12 | 13 | 14 | 15 | 16 | 17 | 18 | 19 | 20 |
| Sub-audio frequency | 97.4 | 100 | 103.5 | 107.2 | 110.9 | 114.8 | 118.8 | 123 | 127.3 | 131.8 |
| Subtone coding | 21 | 22 | 23 | 24 | 25 | 26 | 27 | 28 | 29 | 30 |
| Sub-audio frequency | 136.5 | 141.3 | 146.2 | 151.4 | 156.7 | 162.2 | 167.9 | 173.8 | 179.9 | 186.2 |
| Subtone coding | 31 | 32 | 33 | 34 | 35 | 36 | 37 | 38 | | |
| Sub-audio frequency | 192.8 | 203.5 | 210.7 | 218.1 | 225.7 | 233.6 | 241.8 | 250.3 | | |

Appendix 3: SMD reflow chart

We recommend you should obey the IPC related standards in setting the reflow profile:

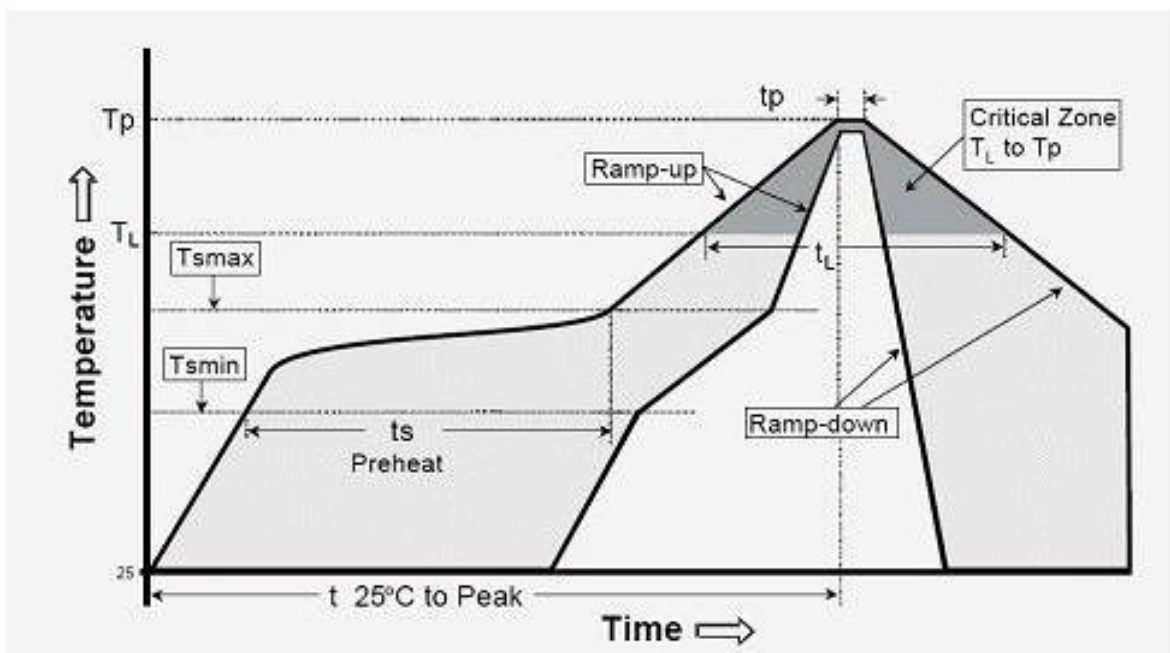

| | |
|---|---|
| IPC/JEDEC J-STD-020B the condition for lead-free reflow soldering | big size components (thickness $\geq 2.5\text{mm}$) |
| The ramp-up rate (Tl to Tp) | 3°C/s (max.) |
| preheat temperature | |
| - Temperature minimum (T _{min}) | 150°C |
| - Temperature maximum (T _{max}) | 200°C |
| - preheat time (t _s) | 60~180s |
| Average ramp-up rate(T _{max} to Tp) | 3°C/s (Max.) |
| - Liquidous temperature(T _L) | 217°C |
| - Time at liquidous(t _L) | 60~150 second |
| peak temperature(T _p) | 245+/-5°C |